

Jefferson®

PROFESSIONAL TOOLS & EQUIPMENT

200L

**INDUSTRIAL
AIR COMPRESSOR**
230V~50Hz • Belt Drive • 10bar • 4.0HP



JEFCIND200L-4.0

User Manual
v.1.1



CONTENTS

Introduction	4
Specifications	4
Unpacking & Assembly	5
Equipment Identification	6
Before First Use	7
Safety Guidelines	8
Warning Labels	10
Safety Valve	11
Operation Guide	11
Maintenance	13
Troubleshooting	14
Environmental Protection	15
WEEE Waste Electrical and Electronic Equipment Statement	15
Parts Diagram - Main Assembly	16
Parts List - Main Assembly	17
Parts Diagram - Pump	18
Parts List - Pump	19
EC Declaration of Conformity	20
Limited Warranty Statement	21

Important: Please read all these instructions before operating this product and save these instructions. This manual has been compiled by Jefferson Tools and is an integrated part of the product with which it's enclosed and should be kept with it for the future reference.

This manual describes the purpose for which the product has been designed and contains all the necessary information to ensure its correct and safe use. We recommend that this manual is read before any operation or, before performing any kind of adjustment to the product and prior to any maintenance tasks. By following all the general safety instructions contained in this manual you will help to ensure operator safety and extend the potential life span of the equipment.

All photographs and drawings in this manual are supplied by Jefferson Tools to help illustrate the operation of the product. Whilst every effort has been made to ensure accuracy of information contained in this manual our policy of continuous improvement determines the right to make modifications without prior warning.

NOTE: The information contained in this Instruction Manual is designed to assist you in the safe operation and maintenance of the compressor. Some illustrations in this Instruction Manual may show details or attachments that differ from those on your own compressor. Contact your nearest Jefferson Dealer if you are unsure about any information included in this manual or require any additional information about the safe use, operation maintenance, or repair of this equipment.

INTRODUCTION

- **200L** Belt-driven compressor suitable for professional workshops
- Fitted with a heavy duty **single-phase 4HP** motor
- Heavy-duty cylinders with alloy heads for improved heat dissipation
- Pressure regulator with moisture trap
- Fitted with 4x anti-vibration feet
- Drive guards offer protection to the fly-wheel and belt assembly
- Powder-coated tank
- Twin pressure gauges showing tank and working pressure
- Welded tank fully-compliant with the latest European manufacturing & safety standards

SPECIFICATIONS

JEFCIND200L-4.0	
Tank Capacity:	200L
Power:	4.0HP / 3.0kW
Input Voltage ~ Frequency:	230V ~ 50Hz / 16A
Maximum Pressure:	10bar (145psi)
Pump Speed:	945rpm
Cylinders:	3
Air Displacement:	15.9 cfm (452 L/min)
Free Air Delivery:	9.4 cfm (266 L/min)
Guaranteed Sound Power:	96 dB LWA
Weight:	NW: 146kg / GW: 182kg
Dimensions:	1365 x 477 x 1033mm

UNPACKING & ASSEMBLY

Upon receipt of the compressor, ensure all components are present and have remained undamaged in transit..Retain the packing materials and packaging in case future transportation of the compressor is necessary. We recommend that the packaging is kept, at least within the period of the guarantee (Fig.1).

WHEELS AND ANTI-VIBRATION FOOT

Pass the 15mm bolt through the wheel, the compressor's frame and secure with the 15mm nut. Locate the wheel onto the axle and secure in place with the internal self locking washer (single use only) (Fig.2).

AIR FILTER

If not already fitted, remove the transit bung from the top of the head and screw the air filter assembly into position.

OIL BREATHER

- For transportation purposes the oil breather is supplied in a separate bag.
- Read the caution plate and take off the plastic bung from the crankcase, add oil and then assembly the oil breather.
- The plastic bung should be retained for future use should it be necessary to transport the unit.

WARNING:

Never operate the compressor with only the plastic transportation bung fitted. Under normal use internal pressure can expel the bung along with oil from the head, possibly leading to damage.

PLEASE NOTE THE FOLLOWING PHOTOGRAPHS & INSTRUCTIONS ARE FOR REFERENCE ONLY AND MAY DIFFER FOR YOUR COMPRESSOR MODEL. PLEASE CONTACT JEFFERSON TOOLS IF YOU NEED ANY ADVICE ON THE ASSEMBLY PROCEDURE.

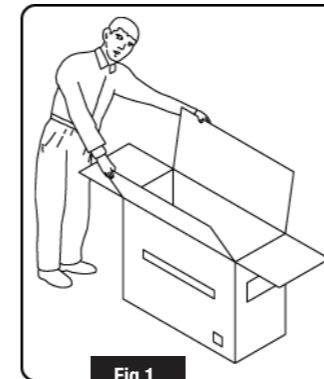

Fig.1

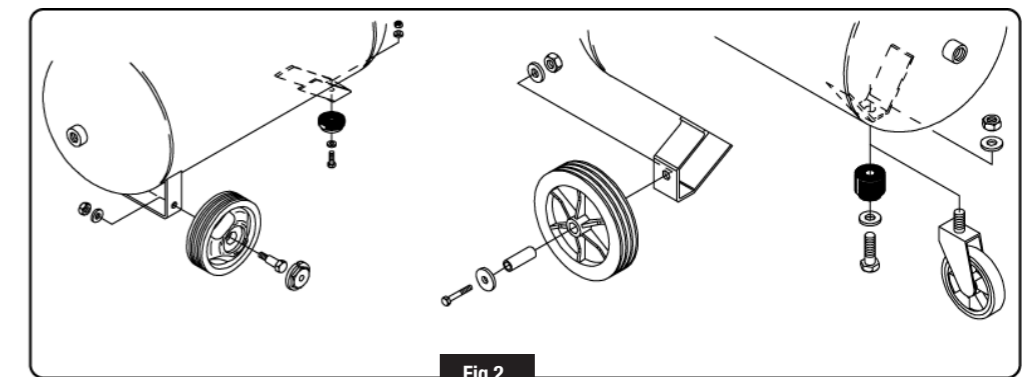

Fig.2

Position the compressor on a flat surface or with a maximum permissible inclination of 10° (Fig.3), in a well aired place, protected against atmospheric agents and not in a place subject to explosion hazard.

If the surface is inclined and smooth, check if the compressor moves while in operation – if it does, secure the wheels with two wedges.

To ensure good ventilation and efficient cooling, the compressor's belt guard must be at least 100cm from any wall (Fig. 4).

Ensure that the compressor is transported correctly, do not overturn it or lift it with hooks or ropes (Fig. 5)

After removing the packing materials, check to ensure the product is in perfect condition and that there are no damaged parts from transit. If in doubt, do not use the product and notify your Jefferson Dealer.

The packaging materials (cardboard, plastic bags, polystyrene, etc), must be disposed of in an appropriate manner and recycled where possible. These materials must not be left within the reach of children as they are potential sources of danger.

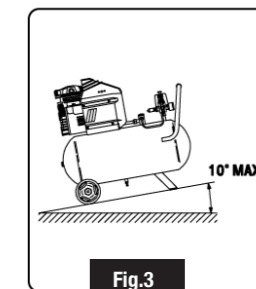

Fig.3

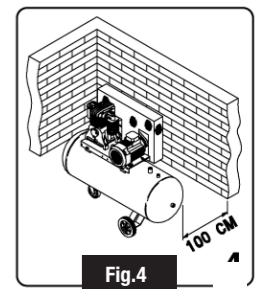

Fig.4

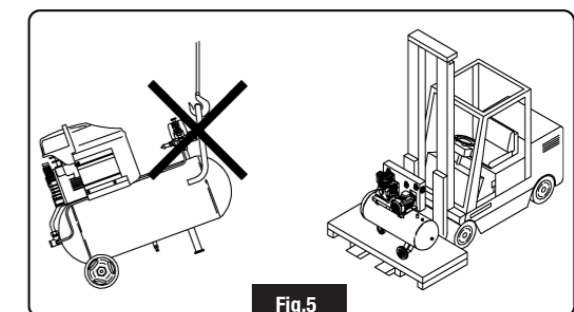
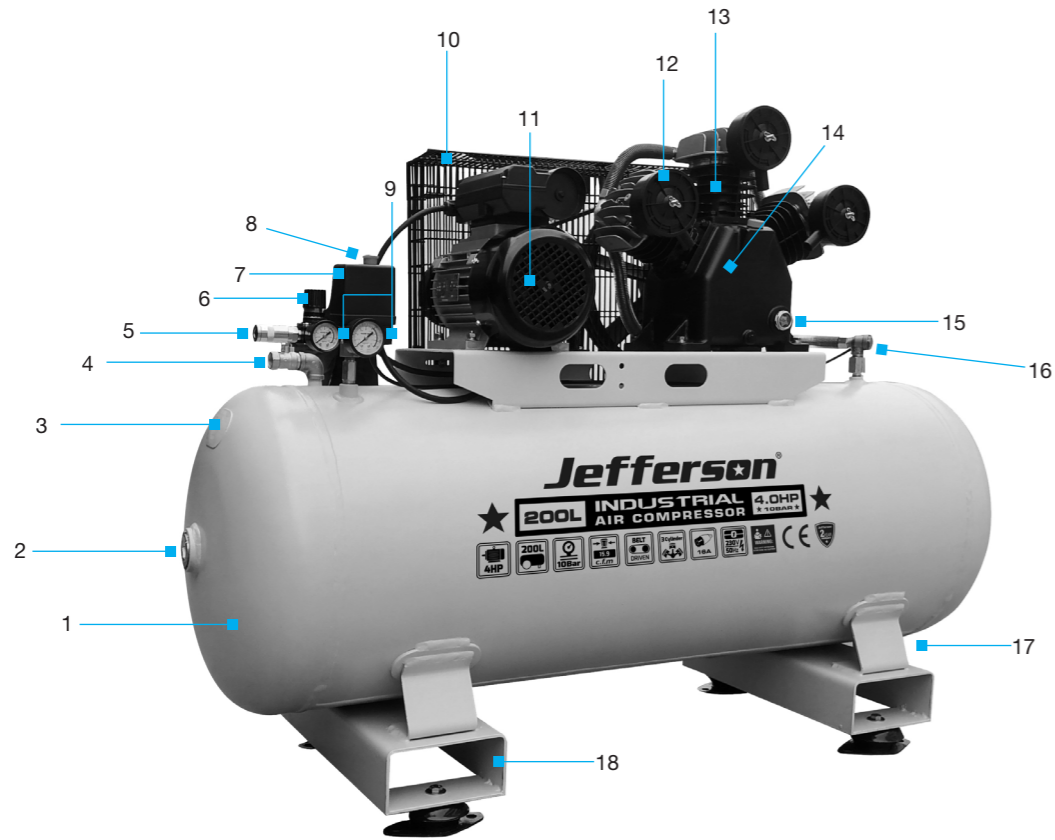

Fig.5

EQUIPMENT IDENTIFICATION



1. Air Reservoir Tank	11. Motor Assembly
2. Tank Outlet (sealed)	12. Air Filter (x3)
3. Tank Rating Plate	13. Cylinder (x3)
4. Safety Valve	14. Pump Assembly
5. Air Outlet / Air Line Coupling	15. Oil Sight Level Glass Tank Drain Valve
6. Pressure Regulator	16. Check Valve
7. Pressure Switch	15. Oil Sight Level Glass Tank Drain Valve
8. On / Off Button	16. Non-Return Valve
9. Pressure Gauge (x2)	17. Condensation Drain Valve
10. Belt Guard Assembly	18. Lifting / Moving Skids with Anti Vibration Feet (x4)

BEFORE FIRST USE

Check oil Level:

Before using the compressor check the oil level using the dipstick. If the oil is not up to the mark it should be topped up with **Jefferson HT68 Compressor Oil** (see Fig.6).

Sight glass / Oil Level:

The compressor oil level can be viewed through the sight glass; the compressor must be on a level surface to measure the oil level through the sight glass accurately (see Fig.7):

- The top of the red dot indicates the full mark
- The bottom of the red dot indicates the low mark

Important: Always ensure that the oil level is correct before operating the compressor.

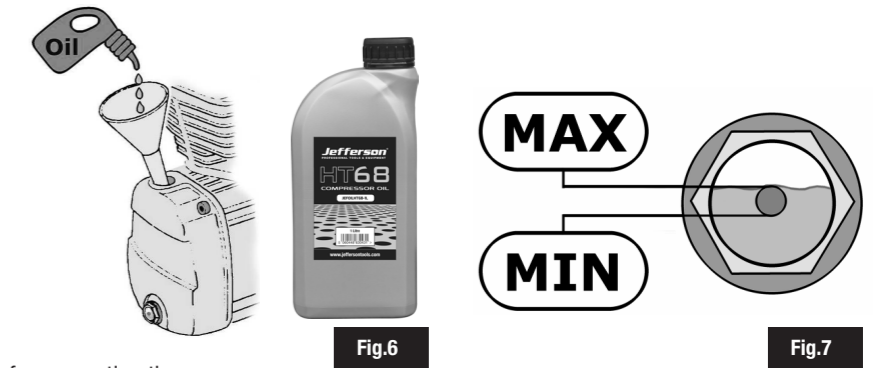

Ensure working environment is suitable for use:

This compressor must be used on a flat, level surface. The maximum safe operating angle in any direction is 10° degrees (see Fig.8).

- Do not operate the compressor on inclines in excess of 10° degrees.
- Serious damage to pump components may result from insufficient lubrication.
- Never use the air compressor on a rooftop or elevated position that could allow the unit to fall or be tipped over.
- Use additional air hose for elevated jobs.

Check power supply is correct for this compressor:

It is essential that the air compressor has an adequate power supply.

Always utilize more air hose before choosing to use an extension lead, as low voltage could cause damage to the motor. (Low voltage damage is not covered under warranty)

Read and understand all the electrical safety guidelines laid out in this manual, follow all applicable local authority safety guidelines.

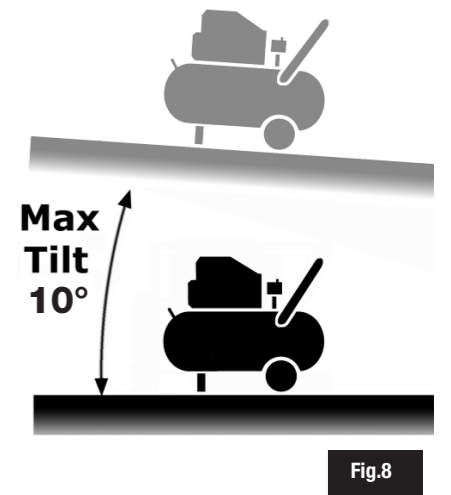

SAFETY GUIDELINES



Read and ensure that you understand all of the operating instructions, safety precautions and warnings in this Instruction Manual before operating or maintaining this compressor. Most accidents that result from compressor operation and maintenance are caused by the failure to observe basic safety rules or precautions. An accident can often be avoided by recognizing a potentially hazardous situation before it occurs, and by observing appropriate safety procedures. Hazards that must be avoided to prevent bodily injury or machine damage are identified by warnings on the compressor and in this Instruction Manual. Never use this compressor or modify it in any way that has not been specifically recommended by the manufacturer. Contact a qualified electrician for advice on any issues relating to electrical safety in your working environment.

ELECTRICAL SAFETY







Ensure that you check the equipment thoroughly to ensure it is safe and fit for purpose before each use. It is important that you inspect all plugs, sockets, power cables and electrical fittings for wear and damage and repair or replace any defective components. The risk of electric shock can be minimised by the correct use of the appropriate electrical safety devices.

- We recommend that you fit a **Residual Current Circuit Breaker (RCCB)** in the main distribution board and that a **Residual Current Device (RCD)** is used when operating this equipment.
- The **Electricity at Work Act 1989** includes legislation that places legal implications on employers to ensure the safety of electrical devices in the workplace. The regulations dictate that all portable equipment must be inspected regularly and tested to ensure that it is safe for use. 'Portable equipment' means any electrical item that can be moved and this is often referred to as **Portable Appliance Testing (PAT)**. PAT testing should be carried out regularly on this equipment by trained, authorised personnel, as required by the legislation.
- The **Health and Safety at Work Act 1974** states that it is the responsibility of the owner of electrical appliances to ensure that both the equipment and working environments are maintained to ensure safe operation at all times.
- Check that all equipment cables are secure, correctly insulated, free from damage, and protected against short circuit and overload before connecting to the power supply. Do not use worn or damaged cables, plugs, sockets or other fittings.
- Ensure that the power supply matches voltage requirements specified on the equipment and that the plug is wired correctly and fitted with the correct fuse.
- If the electrical fuse blows, ensure it is replaced by an identical type of fuse with the same rating.
- Never pull or manoeuvre this equipment into position using the power cable (move using the handle).
- Ensure the power cable is kept away from heat, oil and sharp edges.
- We recommend that the equipment is connected directly to the power supply without the use of extension leads as the resulting voltage drop can reduce motor and pump performance.
- Always disconnect the compressor from the power source and remove the compressed air from the air tank before servicing, inspecting, maintaining, cleaning, replacing or checking any parts.
- Do not carry the compressor while it is connected to its power source or when the air tank is filled with compressed air. Be sure the pressure switch is in the **"Off"** position before connecting the compressor to its power source.
- Do not use the compressor in damp / wet conditions.

EQUIPMENT SAFETY

- Never place your hands, fingers or other body parts near the compressor's moving parts during operation. Ensure that the equipment is isolated from the power supply and all switches in the **OFF** position before carrying out maintenance, repairs or adjustments.
- Never operate this compressor without all guards or safety features in place and in proper working order. If maintenance or servicing requires the removal of a guard or safety features, be sure to replace the guards or safety features before resuming operation of the compressor.
- Always wear safety goggles or equivalent eye protection. Compressed air must never be aimed at anyone or any part of the body.
- When not in use, the compressor should be stored in dry place. Keep out of reach of children. Keep children and animals away from the work area.
- Clear all work areas of unnecessary tools, debris, furniture etc. prior to use. Cluttered work areas can lead to injuries.
- Do not wear loose clothing or jewellery when operating this equipment. They can be caught in moving parts. Wear protective hair covering to contain long hair.
- Follow instructions for lubricating this equipment as required.
- Watch what you are doing and remove any potential distractions before use. Use common sense at all times.
- Do not operate this equipment when you are tired or if you are under the influence of alcohol, drugs or medication that makes you drowsy.
- Check for the correct alignment of moving parts, binding of moving parts, condition of parts, mounting, and air leaks, and any other issues that might affect the safe operation of this equipment. A guard or other part that is damaged should be properly repaired or replaced by an authorized Jefferson service centre unless otherwise indicated elsewhere in this instruction manual. Have defective pressure switches replaced by an authorized service centre. Do not use compressor if the switch does not turn it on and off.
- Operate the compressor according to the instructions provided in this manual. Never allow the compressor to be operated by children, individuals unfamiliar with its operation or unauthorized personnel.
- Keep all screws, bolts, and plates tightly mounted. Check regularly.
- The motor air vent must be kept clean so that air can freely flow at all times. Check for dust build-up frequently and clean as required.
- If the equipment appears to be operating unusually, making strange noises, or otherwise appears defective, stop using it immediately and arrange for repairs by a authorized service centre.
- Solvents such as petrol, thinner, benzene, carbon tetrachloride, and alcohol may damage and crack plastic parts. Do not wipe them with such solvents. Wipe plastic parts with a soft cloth lightly dampened with soapy water and dry thoroughly.
- Only use Jefferson approved replacement parts. Non-approved parts will void your warranty and can lead to malfunction and resulting injuries. Genuine parts are available from Jefferson your dealer.
- Do not modify the compressor for any use other than which it was designed for by the manufacturer. Do not tamper with or attempt to adjust the tank, pressure switch or safety valve. Never strap anything to the tank. Do not subject the tank to impact, vibration, heat, abrasion or corrosive materials.
- Always contact an authorized service centre for advice on any repairs. Unauthorized modification may not only impair the compressor performance but may also result in accident or injury to repair personnel who do not have the required knowledge and technical expertise to perform the repair operations correctly.
- When the compressor is not in use, ensure the pressure switch is turned off, disconnect the equipment from the power source and open the drain cock to discharge the compressed air from the air tank.
- To reduce the risk of burns, do not touch tubes, heads, cylinder and motors. During or immediately after use. Allow equipment to cool down before carrying out maintenance, repairs or adjustments.
- Never direct the output jet of air at persons or animals. Ensure air supply valve is turned **OFF** before disconnecting the air supply hose.
- Read the all safety instructions for any tool or accessory used with the compressor and ensure the safe working pressure of any appliance used exceeds the output pressure of the compressor. If you are using a spray gun it is important to ensure that the work area has sufficient ventilation in place.
- Do not operate in the vicinity of flammable liquids, gases or solids.
- Do not operate the compressor without an air filter or restrict the air flow around the equipment.
- When the compressor is not in use ensure that it is switched off, disconnected from the power supply and the air and moisture drained from the tank.

WARNING LABELS

Label	Potential Hazard	Prevention
 <p>WARNING RISK OF ELECTRICAL SHOCK</p>	<p>Water directed at electrical connections or switches, or objects connected to an electrical circuit, could result in a fatal electrical shock.</p> <p>Moisture or a liquid of any kind may conduct electricity and could result in a fatal electrical shock.</p> <p>Note: This equipment is not waterproof.</p>	<p>Never attempt to clean the air compressor while it is running. Direct any water or spray away from electric outlets and switches.</p> <p>Keep your air compressor out of the elements and well sheltered from rain, snow, dew, water or mist of any kind.</p> <p>Do not use the compressor with the supply cord damaged or with poor quality connections</p>
 <p>DANGER RISK OF EXPLOSION OR FIRE</p>	<p>Operating the air compressor in an explosive environment could result in a fire.</p> <p>Materials placed against or near the air compressor can interfere with its proper ventilation causing overheating and possible ignition of the materials.</p> <p>Improperly stored paint thinners could lead to accidental ignition.</p> <p>Good air flow is important as both the motor and compressor unit are air cooled. Restrictions to or insufficient air flow will cause overheating.</p>	<p>Never spray paint in a confined area with the air compressor.</p> <p>Operate the air compressor in well ventilated areas free from obstructions. Equip areas with fire extinguishers suitable for electrical fires. Do not leave nylon material shirts or jumpers on the compressor.</p> <p>Store paint thinners and other flammable liquids in approved containers, in a secure location away from the work area.</p> <p>Minimum clearance 0.5m / Maximum ambient operating temperature 45°C</p>
 <p>DANGER RISK TO BREATHING</p>	<p>This air compressor does not provide breathable air, the air may be contaminated with mineral based oils and other contaminants which poses the risk of serious lung infection and or injury.</p> <p>Spraying any material without the use of a face mask will result in the ingestion of foreign substances.</p>	<p>Never try to provide breathing air or refill auxiliary breathing apparatus using this compressor.</p> <p>Never spray substances in a closed location occupied by humans or animals always use a face mask when spraying substances</p>
 <p>WARNING RISK OF HOT SURFACES</p>	<p>Contact with hot surfaces, such as the cylinder head, cooling fins or discharge pipe, could result in serious burns.</p> <p>These parts will remain hot for some time after the compressor is shut down.</p>	<p>During operation, touch only the control surfaces of the air compressor. Keep children and animals far away from the air compressor at all times. They may not be able to recognize the hazards of this product.</p> <p>Allow the air compressor to cool before storage.</p>

SAFETY VALVE

IMPORTANT: The safety valves supplied with this equipment are designed and constructed for use exclusively with compressed air, free from impurity. The materials used in construction are suitable for operating the valve at the rated pressure and temperatures. The viton or NBR gasket conserves the resistance characteristics, even in prolonged use. The valve caulking is designed to impede calibration, modification or tampering. Any modification or recalibration of the safety valve will nullify warranty and potentially make the equipment unsafe.

Valve installation must be performed exclusively by Jefferson approved engineers. Checking the integrity of the valve before installation is obligatory. Also, check that the valve pressure is no greater than the operating pressure of the tank or of the system that it is installed with.

- Check that the discharge flow rate of the valve is greater than the quantity of the air to discharge.
- The safety valve must be positioned directly on the tank in a vertical position, in a dry, accessible place protected against the weather and far away from liquids or condensation.
- It must be positioned to allow sufficient space all around for correct air discharge, without causing damage to persons or the surrounding area.
- The valve rod must be free in its movement when discharging.
- The connection between the valve and the part to be protected must be free from all kinds of choking and be as short as possible so as not to reduce the discharge flow rate of the valve itself.
- The connection passage area must be greater than the valve orifice area.
- During installation screw on the valve with a torque spanner using the hexagonal part of the body.
- Apply a maximum torque of **30Nm**, paying attention not to cause any deformation; using pincers, pliers, hammers or tools other than a hexagonal spanner is forbidden and will void warranty.
- Check that the inlet hole and the shutter are not blocked by glue, Teflon or similar materials that could bind the shutter or other functional components.
- If the valve is replaced the compressed air contained in the system must be discharged first.

WARNING:

Jefferson Tools cannot take any responsibility for damage caused to persons and/or things due to failure to observe these instructions.

OPERATION GUIDE

ON/OFF SWITCH

Prior to connecting the compressor to the power supply, ensure the pressure switch is on the **OFF** position. On initial start-up open the reservoir condensate drain bung (A) (Fig.10), adjust the pressure regulator (B) (Fig.11) to the maximum pressure. Unscrew the bung anti-clockwise to open valve.

Pull the pressure switch (C) up to start the compressor.

NOTE: The switch may be a "Lever" or "Button" type as shown in (Fig.11), depending on your compressor model.

Allow the machine to run for 10 minutes with the air escaping from the reservoir tank before closing the drain bung (A).

Ensure the tank pressure reaches 10 bar as indicated on the gauge (D) before the pressure switch shuts off the motor.

NOTE: When the drain bung is closed the tone from the motor will change. The compressor motor will automatically restart when the tank pressure drops to approximately 3-4 bar less than the maximum pressure.

WARNING: Never stop the compressor using the mains connection. Always switch off the compressor by pressing the pressure switch button down. The compressed air will be vented from the head and allowing an easy re-start.

NOTE: During correct operation a whistle of compressed air escaping/releasing will be heard when the motor stops and a protracted whistle (approx. 20-30 seconds) whenever the compressor is started with no pressure in the tank.

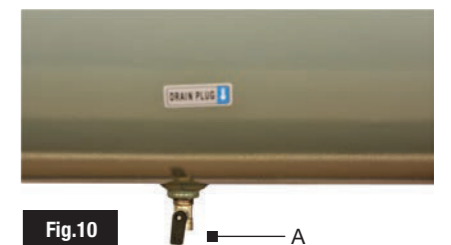

Fig.10 A

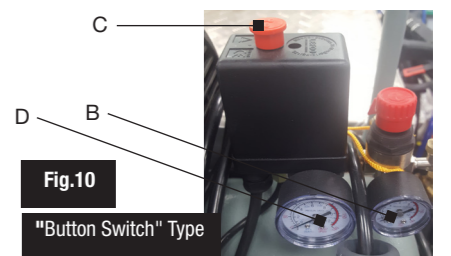

Fig.10 "Button Switch" Type

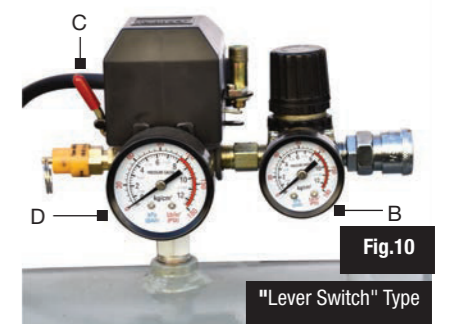

Fig.10 "Lever Switch" Type

OVERLOAD CUT OUT

The compressor is equipped with an overload cut out (E) which operates as a safety device to protect the motor.

Should a fault occur and begin to overheat the motor the overload cut out will automatically operate, cutting power.

This prevents damage occurring to the motor.

Allow 5 minutes for the machine to cool prior to attempting to reset the overload cut out (E). Press button. If after restarting the overload cut out is activated again, switch off the machine, disconnect the power supply and contact your Jefferson Dealer for advice.

NOTE: For technical specifications and detailed instructions please refer to the instructions provided with the specific air tool/accessory. The outlet line pressure from the tank is adjusted using regulator. Rotate the regulator clockwise to increase the pressure or anti-clockwise to decrease. The pressure is indicated on gauge.

ATTENTION: After each use set the pressure to zero to help prolong the life of the regulator and avoid damage.

AIR LINE CONNECTION: The compressor comes equipped with a quick in line female connector. To insert a male connector, pull the collar backwards and insert the male connection. When fully inserted, release the collar. If a different style of connection is required the connector can be replaced.

NOTE: When fitting the replacement ensure the threads are sealed with PTFE tape for an air tight union.

ADJUSTING THE OPERATING PRESSURE

You do not have to use the maximum operating pressure at all times. On the contrary, the pneumatic tool being used often requires less pressure. On compressors supplied with a pressure reducer, operating pressure must be correctly adjusted.

Release the pressure reducer knob by pulling it up, adjust pressure to the required value by turning the knob clockwise to increase pressure and anti-clockwise to reduce it. When you have obtained optimum pressure, lock the knob by pressing it downward (Fig.13). For pressure reducers equipped without a pressure gauge, the set pressure can be seen on the graduated scale located on the reducer body. On pressure reducers equipped with a pressure gauge, pressure can be seen on the gauge itself.



Fig.12

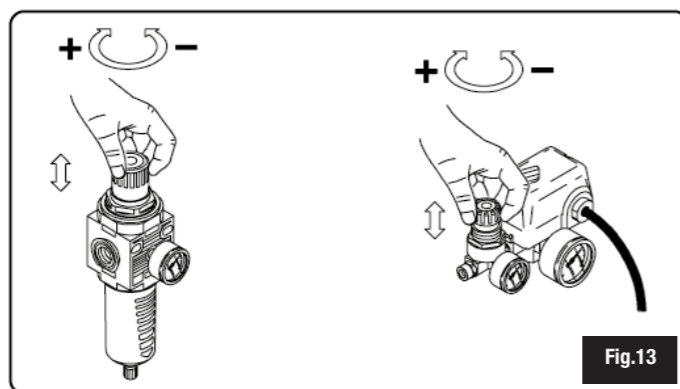

Fig.13

MAINTENANCE

Before attempting any maintenance jobs on the compressor, make sure of the following:

1. The master power switch is turned off and equipment is isolated from the mains supply.
2. Pressure switch and the control unit switches are all in the **OFF** position.
3. All pressure has been removed from the air tank.

Procedure	Daily / Weekly	100Hrs	200Hrs	400Hrs
Check pump oil level	•			
Drain condensate water from the tank	•			
Check for unusual noise and vibration	•			
Inspect equipment for air leaks	•			
Check air filters		•		
Inspect belts	•			
Replace air filters			•	
General cleaning	•			
Check safety relief valve		•		
Check belts for wear / replace		•		
Check and tighten all bolts		•		
Check tubes fittings & electrical connections				•
Service pump / engine				•
Internal & external tank inspection				•
Replace the oil				•

Changing / Filling Compressor Pump Oil

- Ensure the compressor is turned off and disconnected from the power source.
- Allow the compressor pump and other parts to cool off (if changing oil after use).
- Ensure compressor is on a flat and level surface.
- Remove fill cap / plug and place collection container underneath the oil drain cap.
- Remove the oil drain cap, and let the oil drain out.
- Replace the oil cap and be sure to tighten this nut securely (you can use some PTFE tape on the thread to help create a tighter seal before tightening).
- Fill the oil reservoir with a compatible compressor oil (e.g **Jefferson HT68 Compressor Oil**).

Checking / Cleaning the Air Filter

- Ensure the compressor is turned off and disconnected from the power source.
- Allow the compressor pump and other parts to cool off (if changing filter after use).
- Unscrew the filter top from the filter base by turning (generally) counter-clockwise (the direction may vary depending on your filter).
- Separate the filter top cover from the base.
- Remove the filter element from the filter base.
- Blow out dust and debris from the filter element.
- Replace air filter element if required.
- Reconnect filter top to the base and secure filter.

Inspecting / Replacing a Worn Compressor Belt

- If your air compressor is equipped with a protective cage, find the screws or clips that hold the cover in place and remove them.
- Inspect the belt and check for cracks or signs of wear.
- If replacement is necessary, move onto the next step. Otherwise, replace the cage / belt guard and repeat the inspection as scheduled.
- To remove the worn / damaged belt, grasp it firmly and while pulling it over the large pulley, rotate the pulleys by hand and the belt will remove from all pulleys.
- Take the new belt, place it over the small pulley and work it onto the large pulley by hand-turning it in a forward motion until it is securely on the large pulley. Replace the cage / belt guard.

TROUBLESHOOTING

FAULT	CAUSE	REMEDY
Tank pressure drops continually.	Air leak, check all connections.	Locate and rectify leak. Run the compressor at maximum pressure then switch off and disconnect. Brush a soapy water solution over the connections and look for bubbles. Tighten any connections showing leaks. If problem persists contact your authorised service agent.
Tank pressure won't build up.	The drain valve is open.	Close the tank drain valve.
The compressor won't switch off. The safety valve blows off. Compressor does not stop when maximum pressure is reached.	Pressure switch fails to stop motor. Faulty pressure switch.	Contact your authorised service agent.
Tank pressure won't build up and the pump is getting hotter than normal, inlet suction is poor.	The compressor head gasket or valve plate is faulty. Fault with the air filter.	Contact your authorised service agent. Check, clean, replace air filter as required.
There is a leak from the base of the pressure switch when the compressor is running.	Failure of the pressure relief valve. (Located in the base of pressure switch).	Contact your authorised service agent.
There is a leak from the base of the pressure switch when the compressor is stopped.	The non-return valve (from the tank) is leaking.	Disassemble and clean, if necessary replace valve insert. Contact your authorised service agent.
The compressor is noisy with metallic clangs / knocks.	Bearing or piston problem. Low oil level.	Stop the compressor and contact a specialized service technician.
The compressor sounds like it is trying to start (motor makes a humming noise).	Air pressure trapped on piston is resisting the starting effort. Faulty capacitor or fault within the electric motor.	Turn unit off and on again using the pressure switch. This will vent air from the delivery tube. Stop the compressor and contact a specialized service technician.
Overload switch activated.	Startup load may have activated overload switch. Extension lead is too long (if in use) Head unloader not functioning.	Leave for a few minutes then press the reset button and restart. Remove the extension lead and test compressor by connecting the compressor as close to the main fuse box as possible. Stop the compressor and contact a specialized service technician.
Air leaks from the safety valve at pressures less than 10 bar.	The safety valve is faulty.	Replace the safety valve.
Compressor stops and will not restart.	Power failure. Motor failure.	Check electrical supply and fuse. Contact your authorised service agent.

ENVIRONMENTAL PROTECTION



Recycle any packaging and unwanted materials instead of disposing of them as waste. All tools, accessories and packaging should be sorted, taken to a recycling centre and disposed of in a manner which is compatible with the environment.

When the product becomes completely unserviceable, reaches the end of its working life and requires disposal, drain off any fluids (if applicable) into approved containers and dispose of the product and the fluids according to local regulations.

WEEE Waste Electrical and Electronic Equipment Statement



Information on Disposal for Users of Waste Electrical & Electronic Equipment

This symbol on the product(s) and / or accompanying documents means that used electrical and electronic products should not be mixed with general household waste. For proper treatment, recovery and recycling, please take this product(s) to designated collection points where it will be accepted free of charge.

For private households:

Dispose of this product at the end of its working life and in compliance with the EU Directive on Waste Electrical and Electronic Equipment (WEEE). Contact your local solid waste authority for recycling information for this equipment.

Disposing of this product correctly will help save valuable resources and prevent any potential negative effects on human health and the environment, which could otherwise arise from inappropriate waste handling.

Please contact your local authority for further details of your nearest designated collection point.

Penalties may be applicable for incorrect disposal of this waste, in accordance with your national legislation.

For business users in the European Union:

If you wish to discard electrical and electronic equipment, please contact your dealer or supplier for further information.

Information on Disposal in other Countries outside the European Union:

This symbol is only valid in the European Union. If you wish to discard this product please contact your local authorities or dealer and ask for the correct method of disposal.

PARTS DIAGRAM - MAIN ASSEMBLY

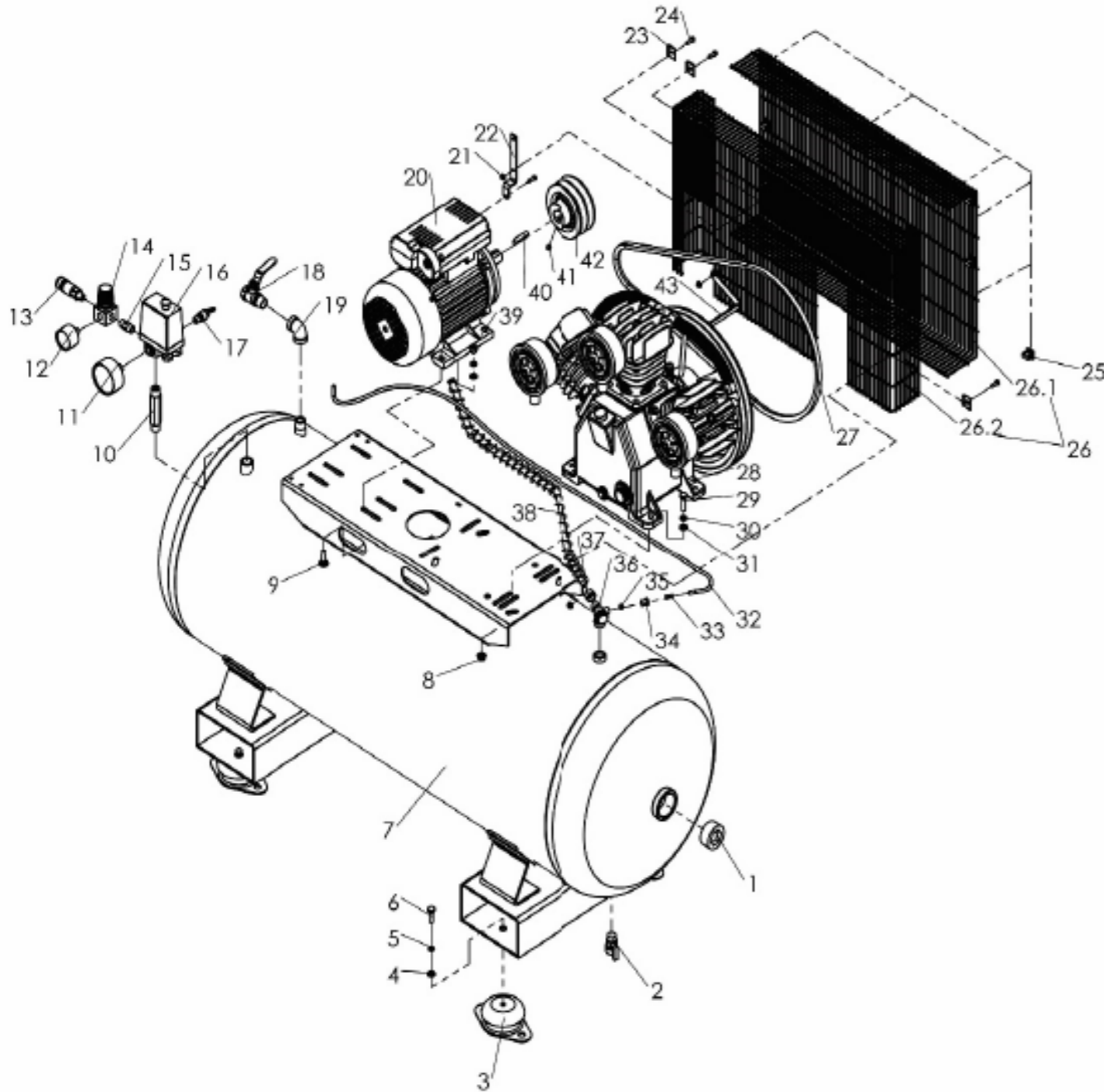

PARTS LIST - MAIN ASSEMBLY

#	Quantity	Description	#	Quantity	Description
1	2	Plug (Socket Head)	26.1	1	Belt Guard Front
2	1	Drian Ball Valve	26.2	1	Belt Guard Rear
3	4	Rubber Foot	27	2	V-Belt
4	4	PL Washer	28	1	Pump Assembly
5	4	SP Washer	29	4	Hex Bolt
6	4	Hex Bolt	30	8	SP Washer
7	1	Air Tank	31	8	PL Washer
8	8	Hex Nut	32	1	Discharge Tube
9	4	Bolt	33	2	Bush
10	1	Nipple	34	1	Bushing (Tube)
11	1	Pressure Gauge	35	1	Sleeve
12	1	Pressure Gauge	36	1	Check Valve
13	1	Quick Coupler Mato	37	2	Sleeve Nut
14	1	Pressure Regulator	38	1	Copper Tube
15	1	Nipple	39	4	Hex Nut
16	1	Pressure Switch	40	1	Key
17	1	Safety Valve	41	1	Set Screw
18	1	Ball Valve	42	1	Motor Pulley
19	1	Elbow Fitting	43	1	Guard Bracket
20	1	Motor			
21	5	Hex Nut			
22	1	Guard Bracket			
23	5	Steel Clip			
24	6	Hex Bolt			
25	7	Plastic Clip			
26	1	Belt Guard Assembly			

PARTS DIAGRAM - PUMP

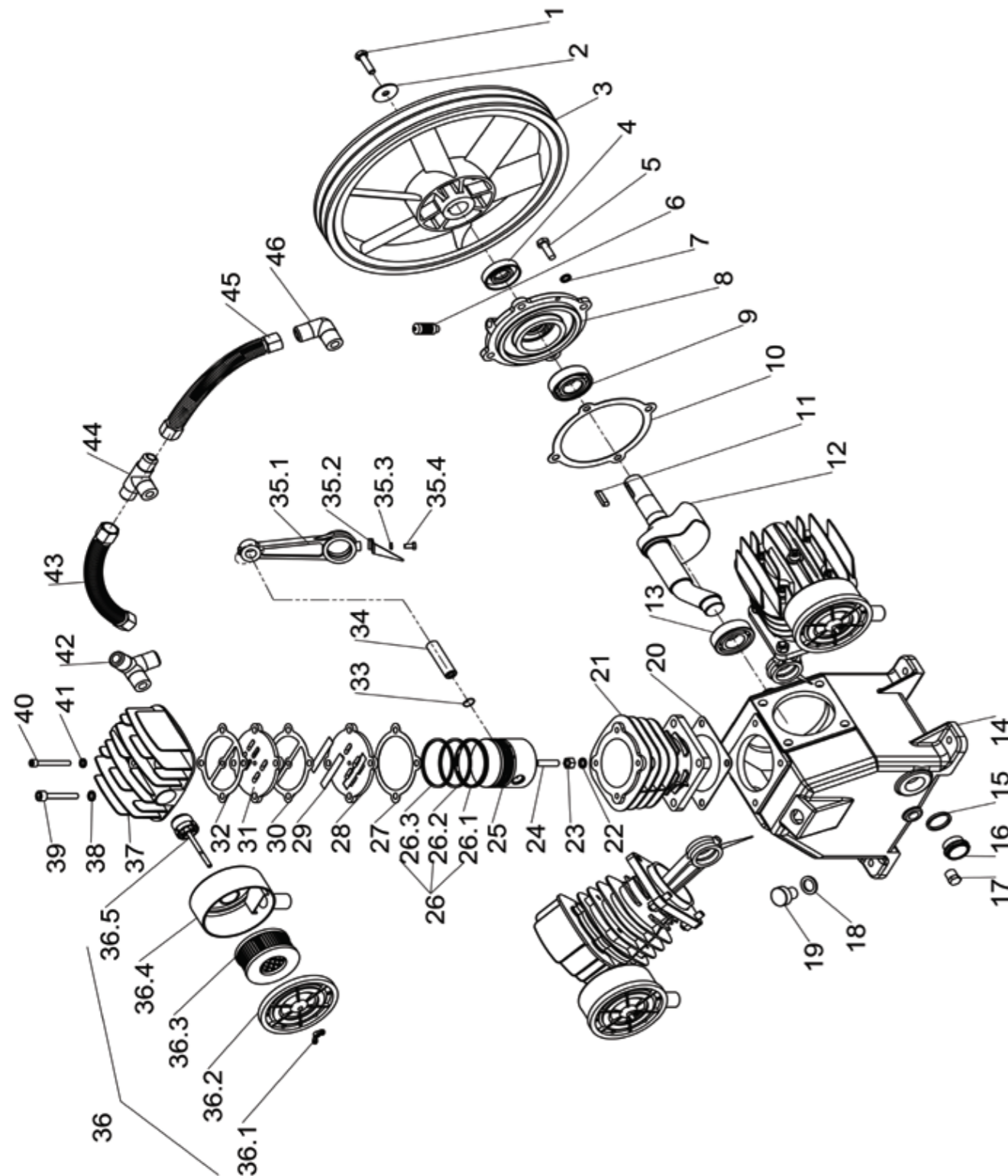

PARTS LIST - PUMP

#	Quantity	Description	#	Quantity	Description
1	1	Hex Bolt	27	3	Gasket (Valve)
2	1	PL Washer	28	6	Valve Plate
3	1	Flywheel	29	6	Blade Valve
4	1	Oil Seal	30	3	Gasket Valve
5	4	Hex Bolt	31	6	Valve Plate
6	1	Breather	32	3	Gasket (Cylinder Cover)
7	4	SP Washer	33	6	Circlip
8	1	Front Cover	34	3	Piston Pin
9	1	Bearing 6204	35.1	3	Connecting Rod
10	1	Gasket, Front Cover	35.2	3	Oil Finger
11	1	Key	35.3	3	SP Washer
12	1	Crankshaft	35.4	3	Hex Bolt
13	1	Bearing 6205	36	3	Air Filter Assembly
14	1	Crankcase	36.1	3	Nut Butterfly
15	1	O-Ring	36.2	3	Case (Rear)
16	1	Oil Sight Glass	36.3	3	Element
17	1	Plug	36.4	3	Case (Front)
18	1	O Ring	36.5	3	Screw
19	1	Oil cap	37	3	Cylinder Head
20	3	Cylinder gasket	38	12	Sp Washer
21	3	Cylinder	39	12	Hex Bolt
22	12	SP.Washer	40	3	Hex Bolt
23	12	Hex.Nut	41	3	SP Washer
24	12	Stud bolt	42	1	3-Way Manifold Nipple
25	3	Piston	43	1	Copper Tube
26	3	Piston ring Kit	44	1	3-Way Manifold Nipple
26.1	3	Oil Ring	45	4	Sleeve Nut
26.2	3	Compression Ring	46	1	Elbow Fitting
26.3	3	Scraping Ring			

Jefferson
PROFESSIONAL TOOLS & EQUIPMENT

Parts & Servicing

For Jefferson approved replacement parts contact your nearest dealer or contact Jefferson tools

Telephone: +44 (0)1244 646 048

Fax: +44 (0)1244 241 191

Email: warranty@jeffersonstools.com

EC DECLARATION OF CONFORMITY

We, Jefferson Professional Tools & Equipment, as the authorised European Community representative of the manufacturer, declare that the following equipment conforms to the requirements of the following Directives:

Directive:	Description:	Notified Body:
2000/14/EC (as amended)	Noise Emission in the Environment by Equipment for Use Outdoors	Ente Certificazione Macchine Srl Via Ca' Bella, 243 – Loc. Castello Di Serravalle – 40053 Valsamoggia (Bo) - Italy #1282
2014/30/EU (as amended)	Electromagnetic Compatibility	Sede Legale e Uffici Via Donatori di sangue, 9 - 46024 Moglia (MN) #0865
2006/42/EC (as amended)	Machinery Directive	
2014/35/EU (as amended)	Low Voltage Directive	
2014/29/EU (as amended)	Simple Pressure Vessels Directive	Technicka Inspekcia A.s. Trnavska Cesta 56 821 01 Bratislava Country : Slovakia #1354

Equipment Category: Air Compressor (Item 8)
Model Number: JEFCIND200L-4.0
Product Name / Description: 200L Compressor • 4HP • 10Bar • 230V~50Hz

Measured Sound Power Level: 96dB (Lwa)
Guaranteed Sound Power Level: 96dB (Lwa)

Signed by: Stephen McIntyre

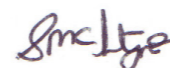

Position in the company: Operations Director
Date: 22nd May 2018

Name and address of manufacturer or authorised representative:
Jefferson Tools, Herons Way, Chester Business Park, Chester, United Kingdom, CH4 9QR
Telephone: +44 (0)1244 646 048
Fax: +44 (0)1244 241 191
Email: enquiries@jeffersonstools.com

LIMITED WARRANTY STATEMENT

Jefferson Professional Tools & Equipment, or hereafter "Jefferson" warrants its customers that its products will be free of defects in workmanship or material. Jefferson shall, upon suitable notification, correct any defects, by repair or replacement, of any parts or components of this product that are determined by Jefferson to be faulty or defective.

This warranty is void if the equipment has been subjected to improper installation, storage, alteration, abnormal operations, improper care, service or repair.

Warranty Period

Jefferson will assume both the parts and labour expense of correcting defects during the stated warranty periods below.

All warranty periods start from the date of purchase from an authorised Jefferson dealer. If proof of purchase is unavailable from the end user, then the date of purchase will be deemed to be 3 months after the initial sale to the distributor.

2 Years

- JEFCIND200L-4.0 • 200L Compressor • 4HP • 10Bar • 230~50Hz

90 Days

- All replacement parts purchased **outside** of the warranty period

Important: All parts used in the repair or replacement of warranty covered equipment will be subject to a minimum of 90 days cover or the remaining duration of the warranty period from the original date of purchase.

Warranty Registration / Activation

You can register and activate your warranty by visiting the Jefferson Tools website using the following address: www.jeffersonstools.com/warranty and completing the online form. Online warranty registration is recommended as it eliminates the need to provide proof of purchase should a warranty claim be necessary.

Warranty Repair

Should Jefferson confirm the existence of any defect covered by this warranty the defect will be corrected by repair or replacement at an authorized Jefferson dealer or repair centre.

Packaging & Freight Costs

The customer is responsible for the packaging of the equipment and making it ready for collection. Jefferson will arrange collection and transportation of any equipment returned under warranty. Upon inspection of the equipment, if no defect can be found or the equipment is not covered under the terms of the Jefferson warranty, the customer will be liable for any labour and return transportation costs incurred.

These costs will be agreed with the customer before the machine is returned.

* Jefferson reserve the right to void any warranty for damages identified as being caused through misuse

Warranty Limitations

Jefferson will not accept responsibility or liability for repairs made by unauthorised technicians or engineers. Jefferson's liability under this warranty will not exceed the cost of correcting the defect of the Jefferson products.

Jefferson will not be liable for incidental or consequential damages (such as loss of business or hire of substitute equipment etc.) caused by the defect or the time involved to correct the defect. This written warranty is the only express warranty provided by Jefferson with respect to its products.

Any warranties of merchantability are limited to the duration of this limited warranty for the equipment involved.

Jefferson is not responsible for cable wear due to flexing and abrasion. The end user is responsible for routine inspection of cables for possible wear and to correct any issues prior to cable failure.

Claiming Warranty Coverage

The end user must contact Jefferson Professional Tools & Equipment (Tel: +44 (0) 1244 646 048) or their nearest authorised Jefferson dealer where final determination of the warranty coverage can be ascertained.

Step 1 - Reporting the Defect

Online Method:

- Visit our website www.jeffersonstools.com/warranty and complete the Warranty Returns form. You can complete the form online and submit it to us directly or download the form to print out and return by post.

Telephone Method:

Contact your Jefferson dealer or sales representative with the following information:

- Model number
- Serial number (usually located on the specification plate)
- Date of purchase

A Warranty Returns form will be sent to you for completion and return by post or fax, together with details of your nearest authorised Jefferson repair centre. On receipt of this form Jefferson will arrange to collect the equipment from you at the earliest convenience.

Step 2 - Returning the Equipment

It is the customer's responsibility to ensure that the equipment is appropriately and securely packaged for collection, **together with a copy of the original proof of purchase**. Please note that Jefferson cannot assume any responsibility for any damage incurred to equipment during transit. Any claims against a third party courier will be dealt with under the terms & conditions of their road haulage association directives.

NOTE: Jefferson will be unable to collect or process any warranty requests without a copy of the original proof of purchase.

Step 3 - Assessment and Repair

On receipt, the equipment will be assessed by an authorised Jefferson engineer and it will be determined if the equipment is defective and in need of repair and any repairs needed are covered by the warranty policy. In order to qualify for warranty cover all equipment presented must have been used, serviced and maintained as instructed in the user manual.

Where repair is not covered by the warranty a quotation for repair, labour costs and return delivery will be sent to the customer (normally within 7 working days).

NOTE: If the repair quotation is not accepted Jefferson Professional Tools & Equipment will invoice **1 hour labour time at £30 per hour plus return carriage costs (plus VAT)**.

In cases where no fault can be found with the equipment, or, if incorrect operation of the equipment is identified as the cause of the problem, a minimum of 1 hour labour at **£30 per hour plus carriage costs** will be required before the equipment will be despatched back to the customer.

Any equipment repaired or replaced under warranty will normally be ready for shipment back to the customer within 7 working days upon receipt of the equipment at an authorised Jefferson Repair centre (subject to part availability). Where parts are not immediately available Jefferson will contact you with a revised date for completion of the repair.

General Warranty Enquiries

For any further information relating to Jefferson warranty cover please call **+44 (0) 1244 646 048** or send your enquiry via email to **warranty@jeffersonstools.com**

Disclaimer:

The information in this document is to the best of our knowledge true and accurate, but all recommendations or suggestions are made without guarantee. Since the conditions of use are beyond their control, Jefferson Tools® disclaim any liability for loss or damage suffered from the use of this data or suggestions. Furthermore, no liability is accepted if use of any product in accordance with this data or suggestions infringes any patent. Jefferson Tools® reserve the right to change product specifications and warranty statements without further notification. All images are for illustration purposes only.



IMPORTANT! SAFETY FIRST!

Before attempting to use this product please read all the safety precautions and operating instructions outlined in this manual to reduce the risk of fire, electric shock or personal injury.



Jefferson Tools,
Herons Way,
Chester Business Park,
Chester,
United Kingdom,
CH4 9QR

Tel. +44 (0)1244 646 048
Email: sales@jeffersonstools.com